

# 2050-200i ODOR CONTROL SEWER VALVE

The 2050-200i Odor Control Valve is designed to allow for ventilation and odor control at lift stations, wet wells, vaults containing ARV's and forced mains flowing into gravity fed lines. The valve is constructed from aluminum, and is epoxy coated for protection from the harsh outside environment.

Each valve contains (4) 50lb canisters of media to allow for odor scrubbing where concentrations of H<sub>2</sub>S gas and accompanying CFM are both very high. Our media is engineered in pellet form to allow for excellent airflow thru the media bed. Pellets use a chemisorption process that change the molecules in the H<sub>2</sub>S gas into a non-toxic, odor free compound. Wager media has a removal of sewage odors at 99.5% efficiency. A complementary lab analysis of the media is offered after a 12 month period to help determine the remaining life of the media. Feedback from our lab will greatly assist in determining the proper PM maintenance program for each vent site.

The 2050-200i contains (4) check valves that allow for fresh air intake directly in the lines or tank without any restrictions from the unit's media bed. Optional caps may be provided if fresh air intake is not required.

The 2050-200i fits beautifully into residential as well as commercial locations. Each vent has louvered covers to allow for maximum air flow of deodorized air. Every vent is equipped with lockable latches to prevent tampering.

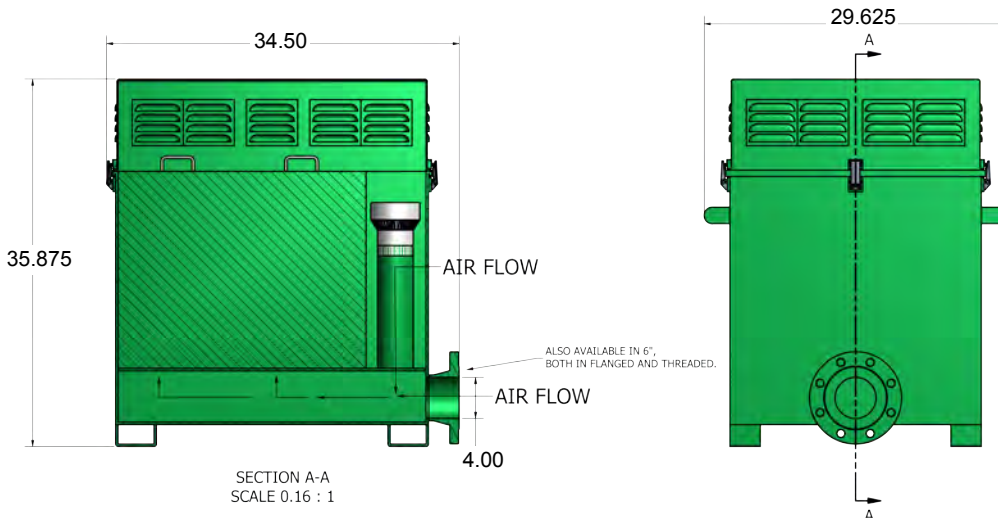

## 2050 -200i SPECIFICATIONS

### LOCATIONS USED

- VAULTS CONTAINING ARV'S
- LIFT STATIONS
- WET WELLS
- FORCED MAINS

### BODY

- ALUMINUM
- EPOXY COATED GRASS GREEN
- LOCKABLE LATCHES
- 4" OR 6" FLANGED OR THREADED CONNECTION

### MEDIA

- 200 LBS OF ODOR CONTROLLING MEDIA
- 4- 50 LBS DROP IN REPLACEABLE CONTAINERS
- MEDIA AND BINS LANDFILL DISPOSABLE
- COMPLIMENTARY LAB ANALYSIS OF MEDIA AFTER 12 MONTHS OF SERVICE



**WAGER**  
COMPANY

WWW.WAGERUSA.COM  
Toll Free USA: 800-562-7024